

This document consists of proprietary information and is confidential. Any use, reproduction, distribution, or disclosure of this information is strictly prohibited without the express written consent of PISAS.

COPYRIGHT PERFORMANCE INTERCONNECT SAS. All Rights Reserved.

ZONE	REV.	DESCRIPTION	DATE	APPROVED
D1	1	CUSTOMER REFERENCE DRAWING	2025-11-18	
A6	2	BOM PNS CORRECTION	2026-03-18	

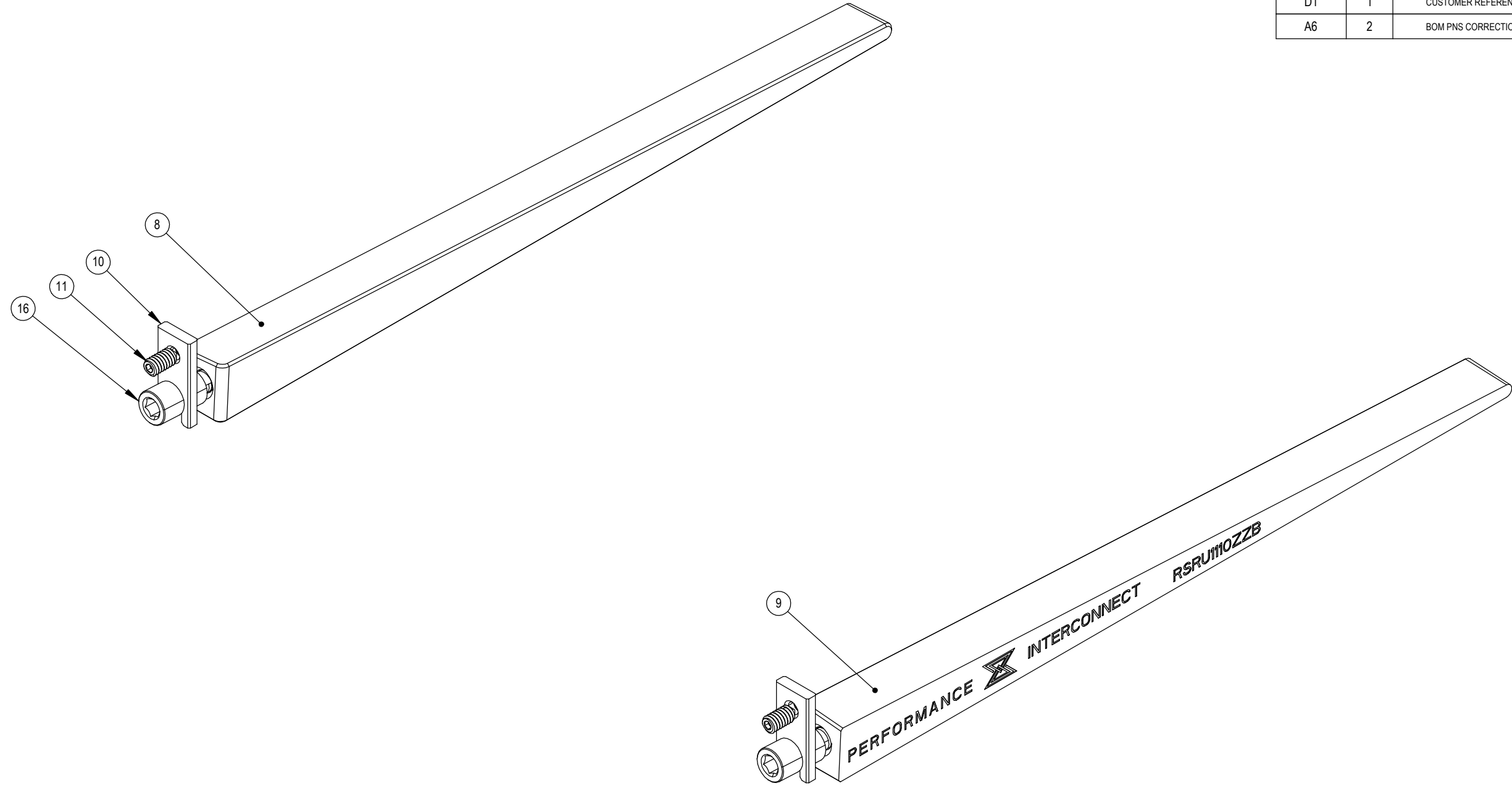

ITEM NO.	PART NUMBER	DESCRIPTION	QTY.
8	RSLU1110ZZB	SOLID RETAINER 394 W/mK	1
9	RSRU1110ZZB	SOLID RETAINER 394 W/mK	1
10	LSBU5040ZZB	SPRING LOCKING BRACKET	2
11	SSSH02	SET SCREW	2
16	LSSU4040ZZB	DRIVE BOLT	2

UNLESS OTHERWISE SPECIFIED:		NAME	DATE	PERFORMANCE INTERCONNECT SAS	
DIMENSIONS ARE IN MM		DRAWN		TITLE:	
TOLERANCES ON DECIMAL:		CHECKED		VPX SECONDARY RETAINER KIT	
.X	+/- 0.20	ENG APPR.		SIZE DWG. NO.	
.XX	+/- 0.10	MFG APPR.		B	RSBK1112ZZB
.XXX	+/- 0.05	Q.A.		REV.	2
X/X	+/-			SCALE: 2:1 WEIGHT: SHEET 1 OF 1	
ANGLE	+/- HOLE DIA. +/-0.08				
MATERIAL	NA	REMOVE ALL BURRS AND SHARP EDGES			
FINISH	NA	DO NOT SCALE DRAWING			